



Item # _____

Model 829A Manual Gravity Feed Slicer



Manual Gravity Feed Slicer Model 829A



Model 829A



Safety and Convenience Features

Berkel Model 829A manual gravity feed slicer features Berkel's hollow ground chromium-plated, carbon steel knife and built-in, single lever, dual-action sharpener with convenient handle located on the sharpener cover. The permanent, tapered guard covers the non-slicing portion of the knife, even when the center plate is removed. The 45° table makes product feed easier, creating more consistent and uniform slices with less waste. The 1/2 HP motor, 14" knife and large product table are ideal for handling oversize meats, cheeses and a variety of other products. The 829A is easy to clean and disassembles quickly without tools.

Standard Features

- ▶ 1-speed, 1/2 HP, totally enclosed and permanently lubricated knife motor
- ▶ Furnished in 115/60/1, 2.9 amp, AC, ETL listed
- ▶ Finish is stainless steel and sanitary anodized aluminum; unit disassembles quickly without tools for easy cleaning
- ▶ 45° Product table
- ▶ Nominal 14" (350 mm) diameter; hollow ground, hardened and polished forged chromium-plated carbon steel knife
- ▶ Carriage handles food up to 11" (280 mm) wide, by 8-1/2" (216 mm) high or 8-1/2" (216 mm) diameter
- ▶ Precise slice adjustment to a thickness of 3/4" (19 mm)
- ▶ Built-in, non-removable, top-mounted, two stone knife sharpener with single lever, dual-action system
- ▶ Permanent, tapered knife ring guard covers non-slicing portion of knife even when the center plate is removed; ring guard design provides more room behind the knife for easy cleaning
- ▶ Positive, moisture protected, rotary on/off switch and power indicator light
- ▶ Attached 6-foot, flexible, 3-wire cord and plug for grounded receptacle

Approved By: _____ Date _____

Berkel Company • 4406 Technology Drive • South Bend, IN 46628-9700
574-232-8222 • 800-348-0251 • FAX 888-888-2838 • www.berkel.com

Berkel

Model 829A

Manual Gravity Feed Slicer

Model No.	Cutting Capacity	Slice Thickness	Knife Diameter	Product Dimensions		
				Width A	Depth B	Height C
829A	11" (280mm) wide 8-1/2" (216 mm) high 8-1/2" (216 mm) diameter	to 3/4" (19 mm)	14" (350mm)	21" (533 mm)	28" (711 mm)	18" (457 mm)

	Motor	Electrical	Weight Net	Ship	Box Dimensions		
					Width	Depth	Height
829A	1-speed 1/2 HP	115/60/1	91 lbs. (41 kg.)	119 lbs. (54 kg)	34" (864 mm)	29" (737 mm)	30" (762 mm)

Specifications

Motor: 1-speed, 1/2 HP, totally enclosed, permanently lubricated ball bearings, thermally protected.

Electrical: Furnished in 115/60/1, 2.9 amp, AC, ETL listed.

Finish/construction: All food contact areas are stainless steel or anodized aluminum including the pusher, gauge plate, product table, center plate, knife ring guard and one-piece base. Slicer disassembles quickly without tools for easy cleaning.

Knife: Nominal 14" (350 mm) diameter, hollow ground, hardened and polished forged chromium-plated carbon steel.

Cutting Capacity: Carriage handles food up to 11" (280 mm) wide by 8-1/2" (216 mm) high or 8-1/2" (216 mm) diameter.

Slice Thickness: Precision system provides infinite slice adjustment and consistent cuts of hard or soft foods from tissue thin to 3/4" (19 mm).

Full Gravity Feed: Full 45° angle feed requires less mechanical pressure. Equipped with anodized aluminum pusher to hold product and minimize waste.

Knife Sharpener: Built-in, non-removable, top mounted, two stone, dual-action system for a lasting, razor-sharp edge.

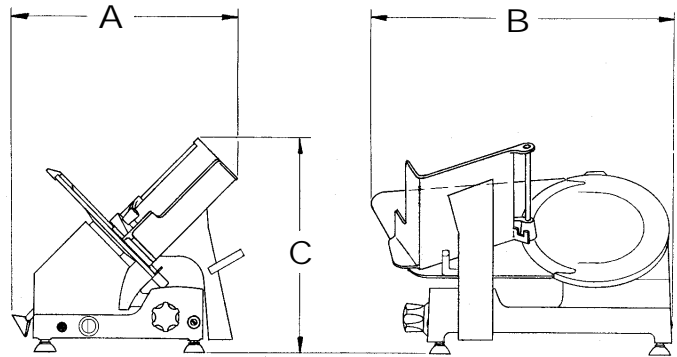

Knife Ring Guard: Permanent, tapered guard covers non-slicing portion of knife edge even when the center plate is removed. The ring guard is designed to provide added room behind the knife for easy cleaning.

On/Off Switch: Highly reliable, moisture resistant, rotary on/off switch and power indicator light.

Cord and Plug: Attached 6-foot, flexible, 3-wire cord and plug for grounded receptacle.

Warranty: All parts, service and travel coverage for one year, excluding wear items.

As we continually strive to improve our products, specifications are necessarily subject to change without notice.

Manual Gravity Feed Slicer Model 829A

Berkel

Berkel Company • 4406 Technology Drive • South Bend, IN 46628-9700
574-232-8222 • 800-348-0251 • FAX 888-888-2838 • www.berkel.com