



Model 825E



Safety and Convenience Features

Berkel Models 823E, 825E and 827E manual gravity feed slicers feature Berkel's hollow ground, chromium-plated carbon steel knife and built-in, dual-action sharpener with convenient handle located on the sharpener cover. The permanent, tapered guard covers the non-slicing portion of the knife even when the sharpener and center plate are removed. The ring guard is designed to provide added room behind the knife for easy cleaning. The compact, space-saving design is ideal for limited kitchen counter space. Units are easy to clean and disassemble quickly without tools.

Item # _____

Model 800E Series Manual Gravity Feed Slicers

- 823E 9" Knife
- 825E 10" Knife
- 827E 12" Knife

Standard Features

- 1-speed, 1/4 HP, totally enclosed and permanently lubricated knife motor
- Furnished in 115/60/1, 2.5 amp, AC, ETL listed.
- Finish is stainless steel and sanitary, anodized aluminum; unit disassembles quickly without tools for easy cleaning
- 45° Product table on 827E model
- 823E is a nominal 9" (220 mm) diameter; 825E is a nominal 10" (250 mm) diameter; 827E is a nominal 12" (300 mm) diameter; hollow ground, hardened and polished forged chromium-plated carbon steel knife
- 823E carriage handles food up to 7-1/8" (181 mm) wide, by 6" (152 mm) high or 6" (152 mm) diameter
 - 825E carriage handles food up to 7-1/2" (191 mm) wide, by 6" (152 mm) high or 7" (178 mm) diameter
 - 827E carriage handles food up to 8-3/4" (222 mm) wide, by 7-1/4" (184 mm) high or 7" (178 mm) diameter
- Precise slice adjustment to a thickness of 9/16" (14 mm)
- Built-in, top-mounted, two stone knife sharpener with dual-action system
- Permanent, tapered knife ring guard covers non-slicing portion of knife even when the sharpener and center plate are removed; ring guard design provides more room behind the knife for easy cleaning
- Positive, moisture protected, on/off rocker switch (823E, 825E); rotary switch (827E); and power indicator light
- Attached 6-foot, flexible, 3-wire cord and plug for grounded receptacle

Approved By: _____ Date _____

Berkel Company • 4406 Technology Drive • South Bend, IN 46628-9700
574-232-8222 • 800-348-0251 • FAX 888-888-2838 • www.berkel.com



Manual Gravity Feed Slicer Model 800E Series

Berkel

Model 800E Series

Manual Gravity Feed Slicers

Manual Gravity Feed Slicer Model 800E Series

Model No.	Cutting Capacity	Slice Thickness	Knife Diameter	Product Dimensions		
				Width A	Depth B	Height C
823E	7-1/8" (181 mm) wide 6" (152 mm) high 6" (152 mm) diameter	to 9/16" (14 mm)	9" (220mm)	15-1/4" (387 mm)	18-3/4" (476 mm)	14-1/2" (368 mm)
825E	7-1/2" (191 mm) wide 6" (152 mm) high 7" (178 mm) diameter	to 9/16" (14 mm)	10" (250mm)	17-1/2" (446 mm)	21-1/8" (537 mm)	15" (381 mm)
827E	8-3/4" (222 mm) wide 7-1/4" (184 mm) high 7" (178 mm) diameter	to 9/16" (14 mm)	12" (300mm)	17-1/4" (438 mm)	22" (559 mm)	16" (406 mm)

	Motor	Electrical	Weight Net	Ship	Box Dimensions		
					Width	Depth	Height
823E	1-speed 1/4 HP	115/60/1	29 lbs. (13 kg.)	36 lbs. (16 kg)	22-1/2" (572 mm)	17-3/4" (451 mm)	16-1/2" (419 mm)
825E	1-speed 1/4 HP	115/60/1	33 lbs. (15 kg.)	40 lbs. (18kg)	24-3/4" (629 mm)	19-3/4" (502 mm)	17-1/2" (445 mm)
827E	1-speed 1/4 HP	115/60/1	41 lbs. (19 kg.)	49 lbs. (22 kg)	24-3/4" (629 mm)	19-3/4" (502 mm)	17-1/2" (445 mm)

Specifications

Motor: 1-speed, 1/4 HP, totally enclosed, permanently lubricated ball bearings, thermally protected.

Electrical: Furnished in 115/60/1, 2.5 amp, AC, ETL listed.

Finish/construction: All food contact areas are stainless steel or anodized aluminum including the pusher, gauge plate, product table, center plate, slice deflector, ring guard and one-piece base. Slicer disassembles quickly without tools for easy cleaning.

Knife: 823E is a nominal 9" (220 mm) diameter; 825E is a nominal 10" (250 mm) diameter; 827E is a nominal 12" (300 mm) diameter; hollow ground, hardened and polished forged chromium-plated carbon steel.

Cutting Capacity: 823E carriage handles food up to 7-1/8" (181 mm) wide by 6" (152 mm) high or 6" (152 mm) diameter.

825E carriage handles food up to 7-1/2" (191 mm) wide by 6" (152 mm) high or 7" (178 mm) diameter.

827E carriage handles food up to 8-3/4" (222 mm) wide by 7-1/4" (184 mm) high or 7" (178 mm) diameter.

Slice Thickness: Precision system provides infinite slice adjustment and consistent cuts of hard or soft foods from tissue thin to 9/16" (14 mm).

Full Gravity Feed: Full 45° angle feed on the 827E requires less mechanical pressure. Equipped with anodized aluminum pusher to hold product and minimize waste.

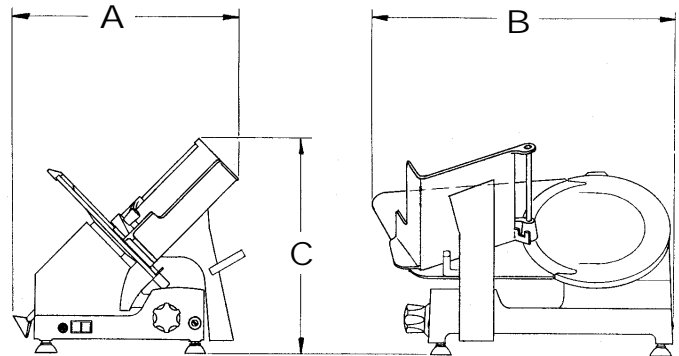

Knife Sharpener: Built-in, top-mounted, two stone dual-action system for a lasting, razor-sharp edge. Unit is removable and submersible for easy cleaning.

Knife Ring Guard: Permanent, tapered guard covers non-slicing portion of knife edge even when the sharpener and center plate are removed. The ring guard is designed to provide added room behind the knife for easy cleaning.

On/Off Switch: Highly reliable, moisture resistant, on/off rocker switch (823E, 825E), rotary switch (827E); and power indicator light.

Cord and Plug: Attached 6-foot, flexible, 3-wire cord and plug for grounded receptacle.

Warranty: All parts, service and travel coverage for one year, excluding wear items.

As we continually strive to improve our products, specifications are necessarily subject to change without notice.

Berkel Company • 4406 Technology Drive • South Bend, IN 46628-9700
574-232-8222 • 800-348-0251 • FAX 888-888-2838 • www.berkel.com

Berkel