

GX250

basic programmable retail printing scale

The Avery Berkel GX250 offers extraordinary value for money. The sophisticated features of many high end products can be found in this economical and compact unit.



Avery Berkel

retail and food service weighing solutions

basic programmable retail printing scale

The stylish and compact GX 250 counter scale offers a number of unique features aimed at enhancing your customer service levels and business efficiency.

The GX250 offers integral thermal printer, which prints labels detailing weight, price and a barcode.

The GX250 features a crisp double-sided green LED display for counter operator and customer to view.

To help save on label consumption and reduce checkout scanning time, the GX250 carries an innovative "ADD" feature, which allows several products to be recorded on a single label.

FEATURES & BENEFITS

◆ Sophistication

- Up to five operators per machine
- Networking of up to nine machines
- Password protected programming
- Operator names
- Barcode printing
- 40 product groups
- 800 PLUs – no extra memory needed
- Six floating vendors (30 operations per vendor)
- Four header lines and two footer lines (24 characters / line) depending on label style. There is a maximum of two header and zero footer lines in label mode.
- Four digit year and time printing
- Automatic Zero Tracking (AZT)
- Tare display
- Management Reports
- 23 direct, and 23 semi-direct PLU access keys
- Keyboard and platter entered tares can be stored and recalled
- Five lines of text print, 24 characters/line for normal font size, 12 characters/line for large font size.

- ◆ **Barcodes** EAN 8 / EAN 13 / UPC 12 & 13
- ◆ **Interfaces** RS485 scale interfaces as standard. Nine scales may be linked in a network.
- ◆ **Host Communications** Compatible with Avery Berkel MX060. Requires "GX Gateway" interface box.
- ◆ **Keyboard** Tactile keyboard with beep, clustered numeric keys
- ◆ **Elegant design** One piece modular design with column mounted display to provide increased visibility for customer and vendor
- ◆ **Display** Two-sided bright green LED
- ◆ **Printer** Thermal label printer
2.3" (60 mm) / second print speed
3.5" (89 mm) diameter paper roll
2.3" (58 mm) print width
3 label lengths – 60, 76, 80 mm

SPECIFICATIONS

- ◆ **Capacities** 30 lb. x 0.01 lb (15 kg x 0.005 kg)
- ◆ **Power Consumption** 110 VAC @ 1.5A
- ◆ **Platter Size** 13" (330 mm) wide X 10" (250 mm) deep
- ◆ **Shipping Weight** 18.5 lb (8.4 kg)
- ◆ **Construction** ABS plastic body. Stainless steel weighing platter
- ◆ **Agency Approvals**
Legal for Trade
NTEP Class III scale
USA COC# 02-041

◆ Dimensions

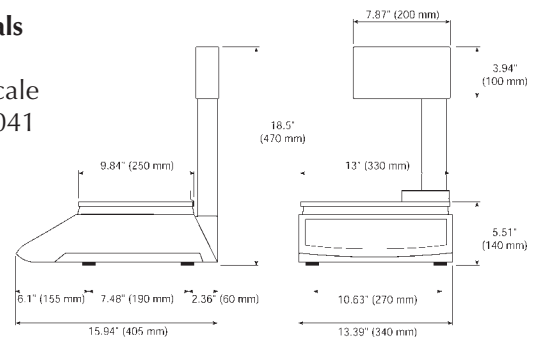

retail and food service weighing solutions

Avery Berkel North America
3133 N 150 E
LaPorte, IN 46350

PH Toll-Free: 800-237-1886
PH: 219-325-9587

FAX Toll-Free: 800-237-2063
FAX: 219-325-9594

sales@AveryBerkelUSA.com
www.AveryBerkelUSA.com



As we continually strive to improve our products, specifications are necessarily subject to change without notice. Product complies with F.C.C..

