

FX220

stylish, compact, tough

*The functions your business needs,
together with uncompromising
Avery Berkel quality make the
FX220 an exceptional value.*



Avery Berkel

retail and food service weighing solutions

FX220

The highest quality at the lowest price

Seeing the name Avery Berkel on a high-quality price-computing scale like the new FX220 should come as no surprise. What will surprise you is the remarkably affordable price.

With the FX220, we've taken weighing technology to a new level to offer an unbeatable package to independent retailers everywhere.

◆ Trade approved capacities for any application

Whatever you want to weigh, from candies to premium delicatessen products, the FX220 delivers the capacity and resolution you need. From 12 lbs. to 60 lbs. in a choice of resolutions to meet your needs – with trade approvals to suit the global economy.

◆ Display options for all

One of the beauties of the FX220 is its wide choice of display options. There's an easy-to-use customer tower display option, and a high-visibility backlit LCD custom display with 0.5" high digits. The customized display may be swiveled 30° to suit customer needs. Plus a whole range of other functions to suit your trade environment, including PLU's; seven-digit unit price/eight-digit total price; and multiple keys for price for 1/4 or 1/2 pound.

◆ PLU Options

The FX220 offers 20 PIN-protected PLU's as standard – including seven hot shot keys for favorites. These may be used with a "quick-set" feature for fast-selling items.

◆ In-store or external trading environment – you've got the power

The FX220 gives you the power to use your scale in any trading situation or environment. It offers a choice of AC adapter, alkaline batteries, and an optional rechargeable module that may be charged in or out of scale.

Without a backlit display, the scale delivers a generous 800 hours (approximately) of battery operation. Take advantage of the battery saver option, and you can conserve the cell life while still benefiting from a backlit display.

◆ Stylish, compact, tough

The FX220 is attractively designed and is tough enough to withstand everyday professional use. It offers the perfect combination of a compact footprint and a spacious weigh plate in high-quality stainless steel. Candy scoop and produce/fish tray options are also available.

◆ New Technology

Digital load cell provides a high-resolution scale, while still achieving a very fast and stable display.

◆ Add Key

Allows for price totaling of weighed and non-weighed products. Total up to 99 transactions.

◆ Cumulative Tare

Allows scale to be used for portion control. Perfect for ingredients (i.e., pizza).

◆ High Results

0.002 capacity option

◆ Manager "PIN"

Allows control of select scale functions.

◆ Options

- Backlight
- Customer Tower
- Rechargeable Battery Module
- Candy Scoop
- Produce/fish Tray



*above: optional produce/fish tray
left: optional customer tower*



stylish, compact, tough

SPECIFICATIONS



- ◆ **Capacity**
 12 lbs. x 0.002 lbs.
 30 lbs. x 0.005 lbs.
 60 lbs. x 0.01 lbs.
- ◆ **Platter** Stainless steel platter — 11.8" x 8.7"
- ◆ **Display** LCD custom panel with 0.5" high digits (12 mm)
- ◆ **Keyboard** Membrane keyboard with audio feedback
- ◆ **Electrical**
AC adaptor:
 Input – 120 VAC
 Output – 12 VDC
- ◆ **Weight**
Net: 8.1 lb (3.67 kg)
Shipping: 10.6 lb (4.8 kg)
- ◆ **Options** Backlight, customer tower, rechargeable battery module, candy scoop, produce/fish tray
- ◆ **Agency Approvals**
 Legal for Trade
 NTEP Class III scale
 USA COC# 99-108
 UL listed



DIMENSIONS

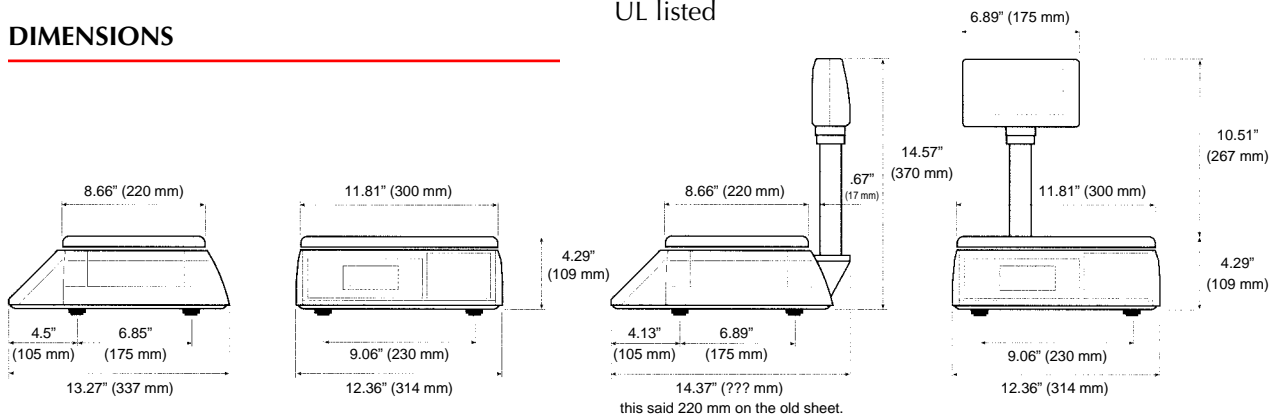

retail and food service weighing solutions

Avery Berkel North America
 3133 E 150 N
 LaPorte, IN 46350

PH Toll-Free: 800-237-1886
PH: 219-325-9587

FAX Toll-Free: 800-237-2063
FAX: 219-325-9594

sales@AveryBerkelUSA.com
 www.AveryBerkelUSA.com



As we continually strive to improve our products, specifications are necessarily subject to change without notice. Product complies with F.C.C. .



A division of Weigh-Tronix, Inc.
 1000 Armstrong Drive
 Fairmont, MN 56031, USA